

DiwiTherm®[®], Resistance Thermometers Model TR75, with digital Display Battery or Solar Powered

WIKA Data Sheet TE 60.75

Applications

- Machinery, plant and tank construction
- Chemical industry
- Food and beverage industry
- Automotive industry
- Sanitary, heating and air-conditioning technology

Special Features

- LCD display
- Versions with insertion sensor, for additional thermowell or with contact bulb for tube skin mounting
- For all standard thermowell designs



DiwiTherm® Resistance Thermometers Model TR75
Fig. left and centre: Battery Powered
Fig. right: Solar Powered

Description

The DiwiTherm® is an ideal combination of a digital indicator and a resistance thermometer. This compact temperature measuring instrument can be used for a variety of applications and works without external power supply. With solar powered thermometers the digital display is operable from a light intensity of 100 Lux.

An extensive range of insertion lengths, neck lengths, thermowell connections etc. are available for these thermometers, so that they are suitable for all thermowell dimensions and applications.

Operation without thermowell is only recommended for specific applications.

The DiwiTherm® can be manufactured with an optional process connection for tube skin temperature measurement.

Specifications	DiwiTherm®	
	battery powered	solar powered
Measuring range		
Scale in °C	-50 ... +199.9 °C or -50 ... +450 °C	-50 ... +150 °C
Scale in °F	-	-50 ... +300 °F
Scale		
Principle	3½-digit, LCD, 17 mm high figures	3½-digit, LCD, 8 mm high figures
Resolution	0.1 °C with measuring range -50 °C ... +199.9 °C 1 °C with measuring range -50 °C ... +450 °C	-50 ... +150 °C
Measuring deviation ¹⁾ per DIN IEC 770, 23 °C ± 5 K	≤ 1 % of upper limit of range	≤ 1 % of scale span
DiwiTherm® with insertion sensor		
Design	Sensor with connection cable ■ Case for panel mounting, with panel mounting flange	
DiwiTherm® for additional thermowell		
Design	Probe spring-loaded Male thread to thermowell ■ Case with extension neck	■ No radial version
Option	■ Case adjustable every angle, axial (rotatable on extension neck 360 °)	
DiwiTherm® for tube skin mounting		
Design	Contact bulb for mounting by means of a strap retainer ■ Case with extension neck	
Option	■ Case adjustable every angle, axial (rotatable on extension neck 360 °) ■ Case for panel mounting, with connection cable and panel mounting flange	
Case		
Nominal size	100	
Material	Stainless steel	
Ingress protection	IP 65 per EN 60529 / IEC 529	
Bezel ring	Cam ring (bayonet type)	
Window	Instrument glass	
Power supply Ub	DC 3.6 V by lithium-battery 3.6 V, size AA (mignon), included in the scope of delivery ²⁾	Solar cell, recommended light intensity > 100 Lux
Operating duration	at least 10 year	
Special features	If the battery falls below 2.7 V, the display switches to "LO" operation	
Electromagnetic compatibility (EMC)		
CE-Conformity	per DIN EN 61326-2 (1998-01)	
Special features		
Sensor	Pt1000	NTC
Ambient and storage temperature	-20 ... +60 °C	-20 ... +60 °C
Vibration (at sensor)	10 ... 500 Hz 5 g IEC 68 2-6	10 ... 500 Hz 5 g IEC 68 2-6
Shock (at sensor)	DIN IEC 68 2-27	DIN IEC 68 2-27
Weight	approx. 1 kg	approx. 0.6 kg

1) In defined measuring range

2) Cannot be exchanged by the customer

DiwiTherm® with insertion sensor

Sensor

Material: stainless steel

Sensor length A ≤ 150 mm: rigid sensor tube

The tubular design is characterised by a rigid construction of the metal sensor tip, therefore tubular designs must not be bent. Inside, the measuring resistor is connected directly to an insulated lead, therefore tubular thermocouples can only be used up to the temperatures specified for the cable (see operating temperatures).

Sensor length from 150 mm: measuring cable (MI cable)
When using a MI lead, the junction between the metal part of the resistance thermometer and the connecting cable is either crimped, rolled or cast, depending on the design. This area should not be submerged into the process and must not be bent. Compression fittings should not be attached to the transition. The type and dimensions of the transition depend largely on the combination between input leads and metal sensor and the sealing requirements.

The diameter of the sensor shall be approx. 1 mm smaller than the hole diameter of the thermowell or the blind hole. Gaps of more than 0.5 mm between thermowell and sensor will have a negative effect on the heat transfer, and they will result in an unfavourable response behaviour of the thermometer.

Sensor length

Sensor Ø in mm	Standard sensor length A (l ₁) in mm		
6	50	100	150
8	-	100	150

Special length are possible.

Process connection

A compression fitting enables easy adaptation to the desired insertion length at the mounting location.

Compression fitting

Material: stainless steel

Male thread G ¼ B (not with probe Ø 8 mm) or G ½ B

Delivery also possible without process connection

Cable

Silicone, with shield, application range -50 °C ... +200 °C

Cable length to customer specification

DiwiTherm® battery powered, model TR75 with insertion sensor, cable outlet on the back, with panel mounting flange for panel mounting

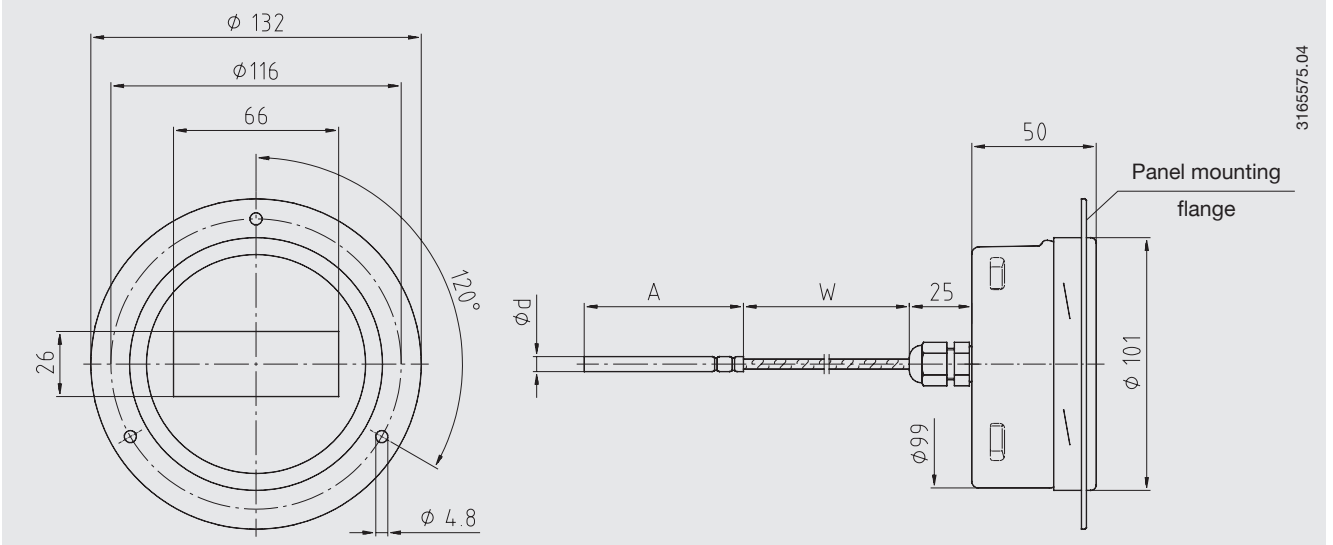

3166575.04

DiwiTherm® solar powered, model TR75 with insertion sensor, cable outlet on the back, with panel mounting flange for panel mounting

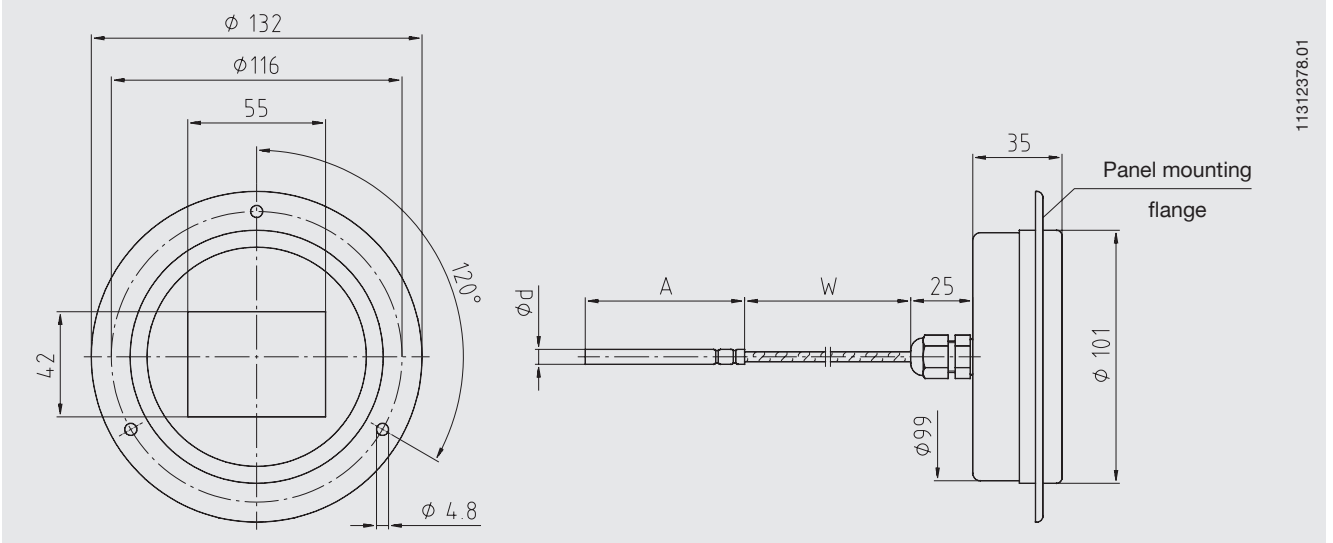

11312378.01

DiwiTherm® for additional thermowell

Probe

Material: stainless steel

The probe is made of a vibration-resistant sheathed measuring cable (MI cable).

The diameter of the probe should be approx. 1 mm less than the diameter of the thermowell hole in which the probe is to be fitted. Gaps of more than 0.5 mm between thermowell and probe will have a negative effect on the heat transfer, and they will result in an unfavourable response behaviour of the thermometer.

When fitting the measuring insert with a thermowell, it is very important to determine the correct insertion length (= thermowell length with bottom thicknesses of ≤ 5.5 mm). In this connection the fact that the measuring insert is spring-loaded (spring travel: max. 10 mm) has to be taken into account in order to ensure that the probe presses against the bottom of the thermowell.

Process connection (standard process connection)

Material: stainless steel

Male thread: G 1/2 B
M14 x 1.5
M18 x 1.5
1/2 NPT

Union nut: G 1/2 B

Swivel nut: G 1/2 B

Extension neck

Material: stainless steel

Extension neck diameter: 12 mm

Standard neck length: 150 mm

other on request

(minimum neck length: 30 mm)

Insertion lengths

Probe \varnothing in mm	Standard insertion length A (l_1) in mm																
3	110	140	145	170	200	205	230	245	260	294	305	345	350	395	410	445	545
6	-	-	-	170	200	205	230	245	260	295	305	345	350	395	410	445	545
8	-	-	-	-	200	205	230	245	260	295	305	345	350	395	410	445	545

Special lengths are possible.

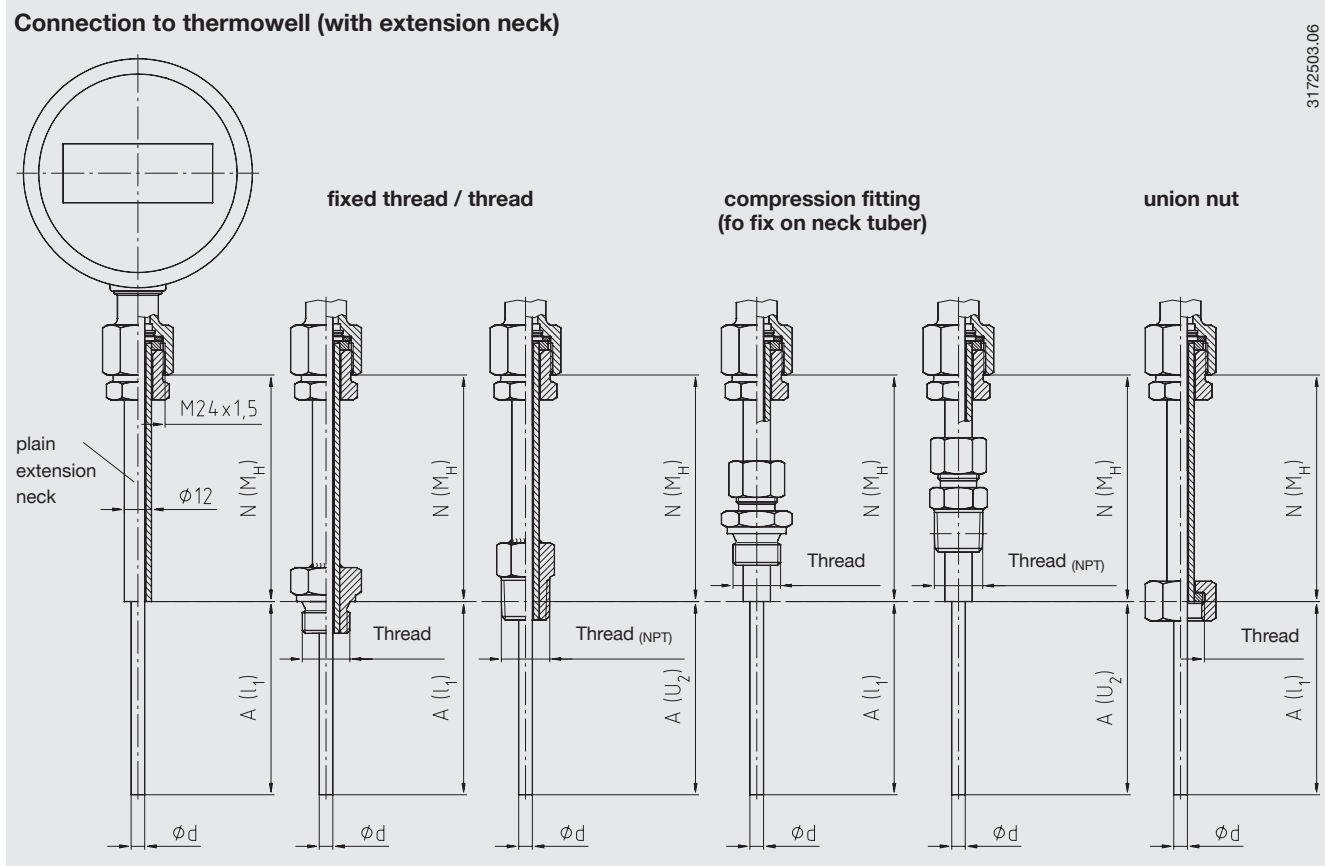

Connection to thermowell

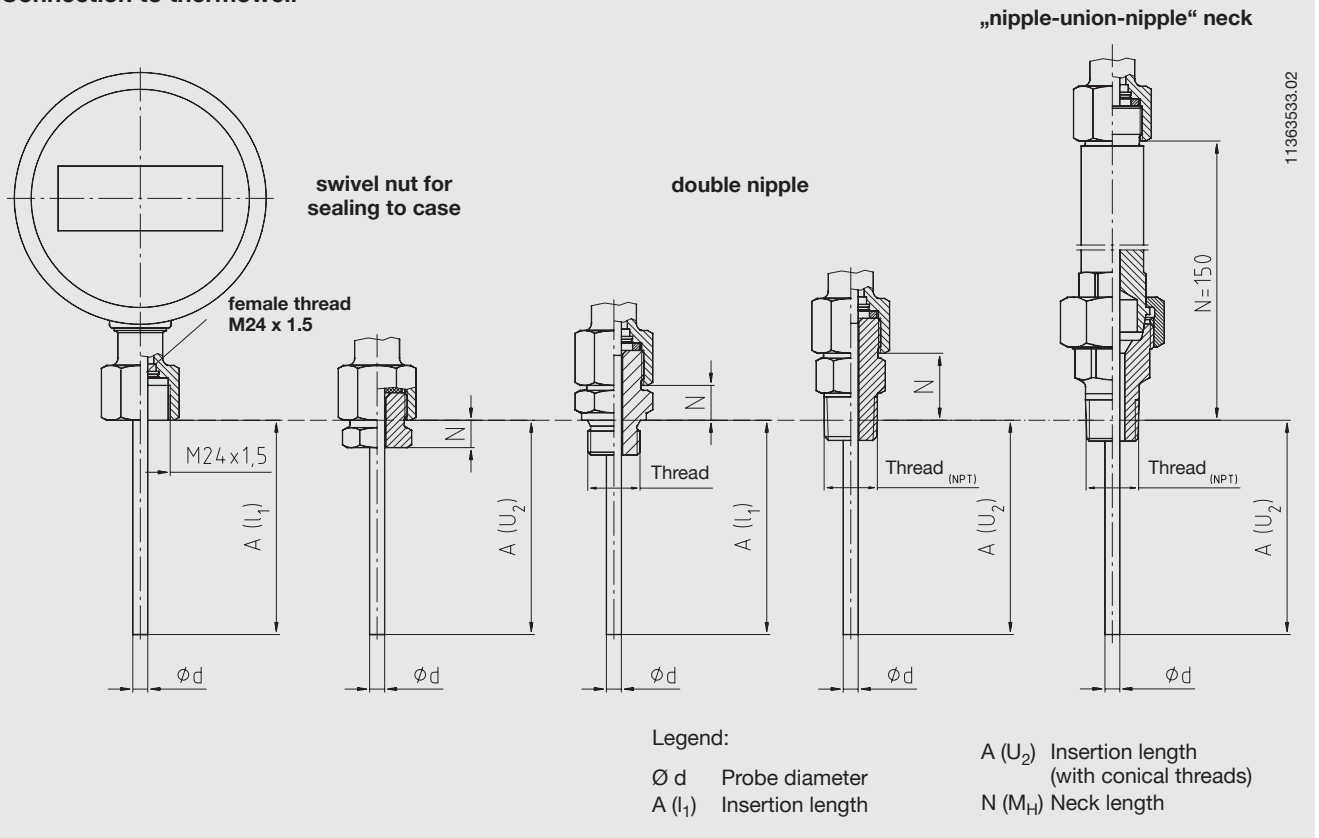

DiwiTherm® Model TR75 for additional thermowell, with extension neck
Connection from case to extension neck: fixed, radial bottom

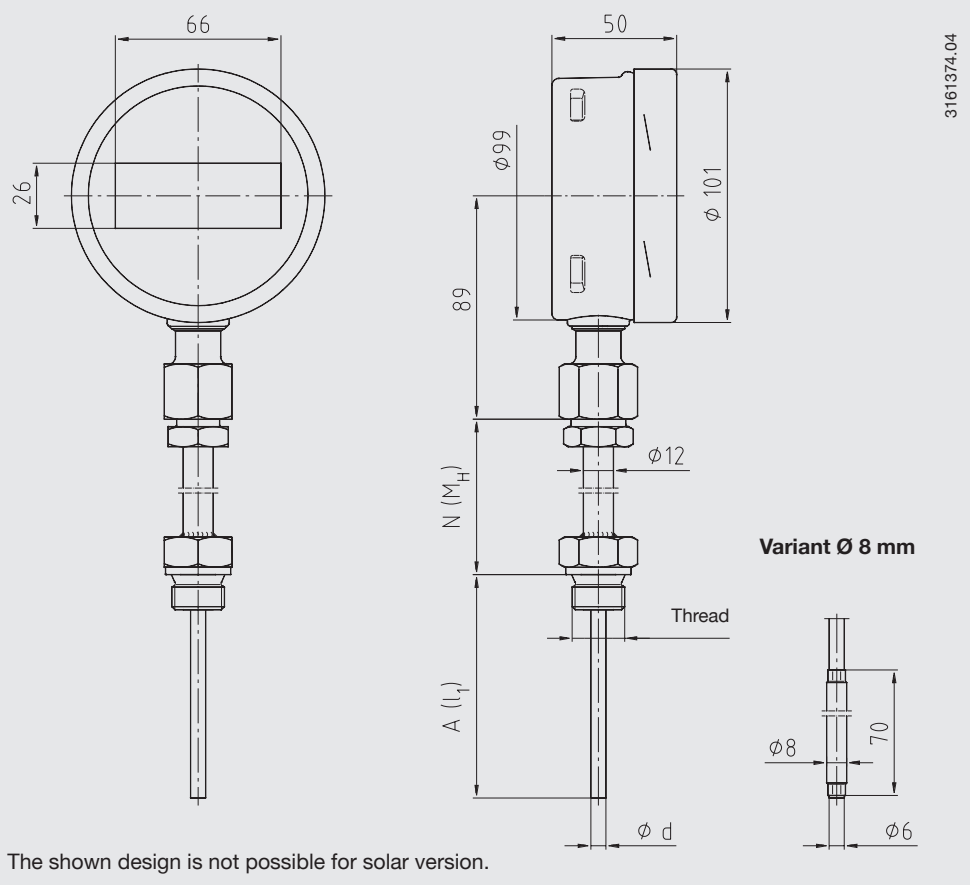

DiwiTherm® Model TR75 for additional thermowell, with extension neck
Connection form case to extension neck: adjustable every angle, centre back

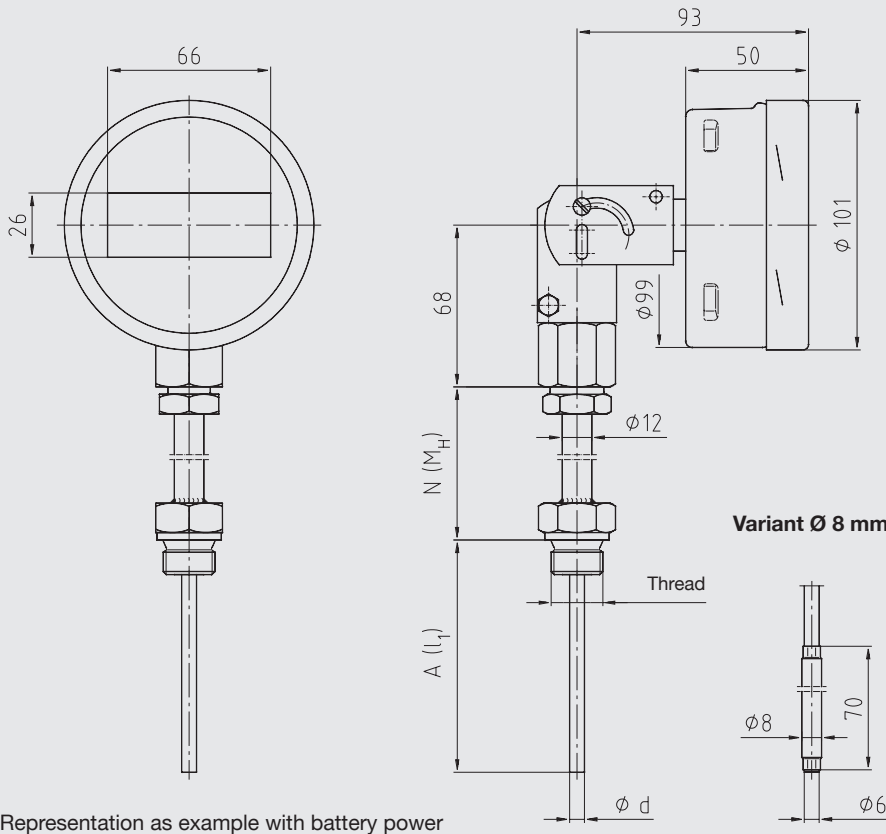

DiwiTherm® for tube skin mounting

Tube skin mounted contact bulb

Material: stainless steel

Fastening tube: 120 mm

Fastening by means of strap retainer (not included in the scope of delivery)

Cable

Silicone, with shield, application range -50 °C ... +200 °C

Cable length to customer specification

DiwiTherm® Model TR75 for tube skin mounting, cable outlet on the back, with panel mounting flange for panel mounting

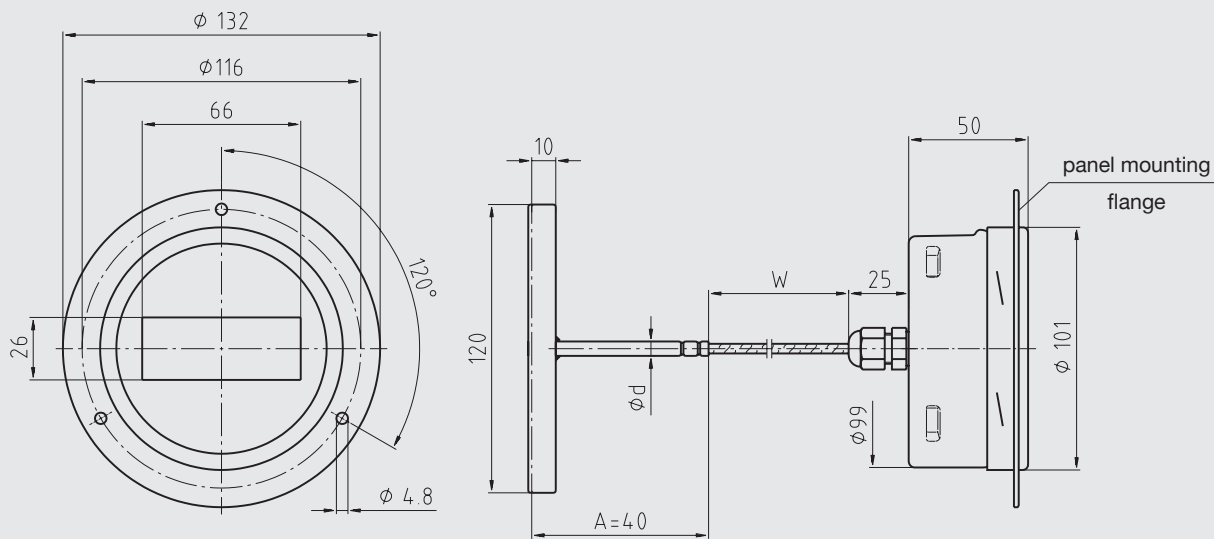

Representation as example with battery power

DiwiTherm® Model TR75 for tube skin mounting, with extension neck
Connection from case to extension neck: fixed, radial bottom

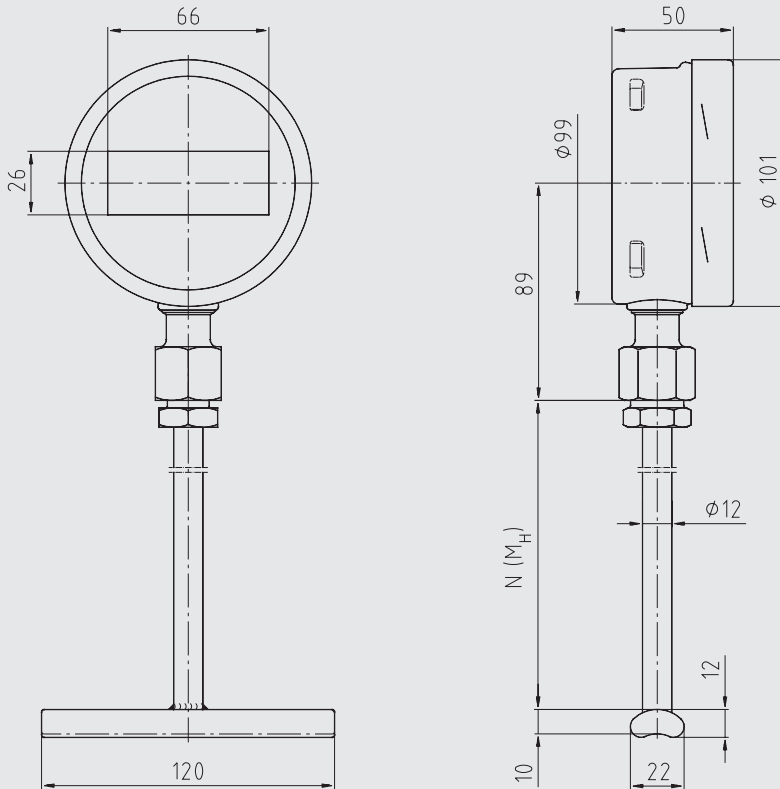

3157541.03

Extension neck

Material: stainless steel
 Extension neck diameter: 12 mm
 Standard neck length: 150 mm
 other on request
 (minimum neck length: 100 mm)

The shown design is not possible for solar version.

DiwiTherm® Model TR75 for tube skin mounting, with extension neck
Connection from case to extension neck: adjustable, centre back

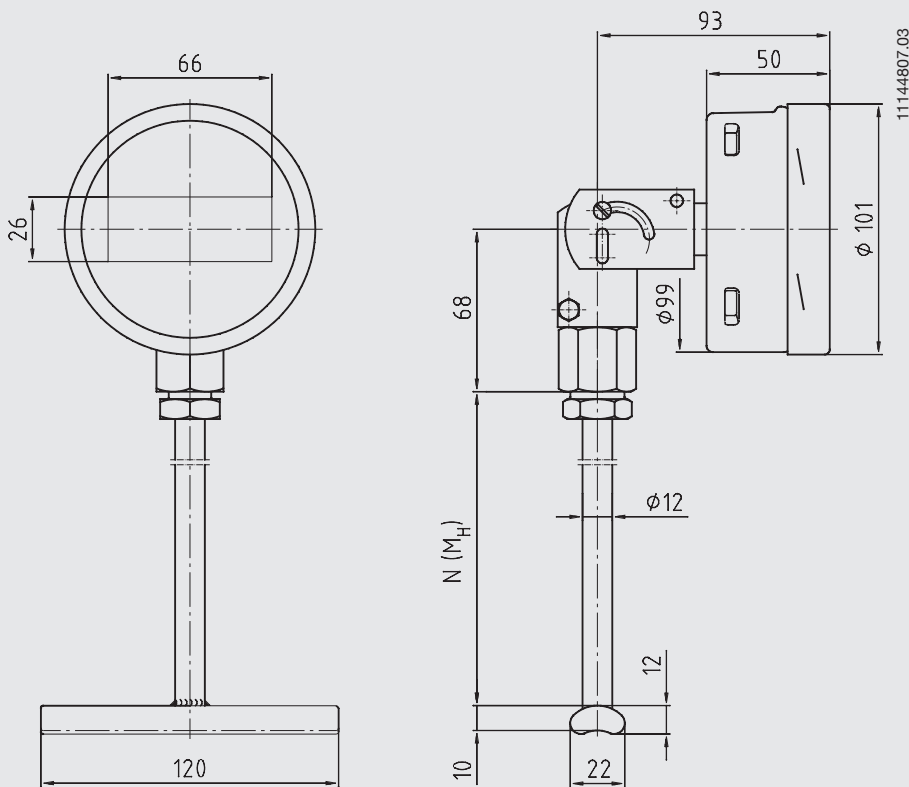

11144807.03

Representation as example with battery power

Mounting instructions for contact bulb

General

The contact bulb has been designed for mounting on a tube or tank skin. The contact bulb is to be mounted so that it lays over the measuring point down its full length. Basic requirements to ensure perfect measurement results are good thermal contact between the skin mounted contact bulb and the outside wall of the tube or tank with minimal heat loss to the ambient from the skin mounted contact bulb and measuring point.

Mounting on tubes

The geometry of the contact bulb has been designed for tubes with external diameters between 20 and 160 mm. Tube clips are adequate for fastening the skin mounted contact bulb to the tube. The skin mounted contact bulb should have direct metallic contact with the measuring point and have firm contact with the surface of the tube. In so far as temperatures under 200 °C are to be expected a heat conductive paste can be used to optimise the heat transmission between skin mounted contact bulb and tube. Lagging must be applied where the skin mounted contact bulb has been mounted to avoid error due to heat loss. This lagging must have sufficient temperature resistance and is not provided with the instrument.

Mounting on tanks

The geometry of the contact bulb has been designed for tanks with an external radius up to 80 mm. If the mounting point of the skin mounting contact bulb on the tank has an external radius greater than 80 mm, we recommend the use of an intermediate piece designed for the respective tank diameter made of a material with good thermal conductivity. The contact bulb should be fastened to the tank by means of an angle bracket with clamping screws, or any similar method.

The skin mounted contact bulb should have direct metallic contact with the measuring point and have firm contact with the surface of the tank. In so far as temperatures under 200 °C are to be expected a heat conductive paste can be used to optimise the heat transmission between skin mounted contact bulb and tank. Lagging must be applied where the skin mounted contact bulb has been mounted to avoid error due to heat loss. This lagging must have sufficient temperature resistance and is not provided with the instrument.

Tube clip mounting

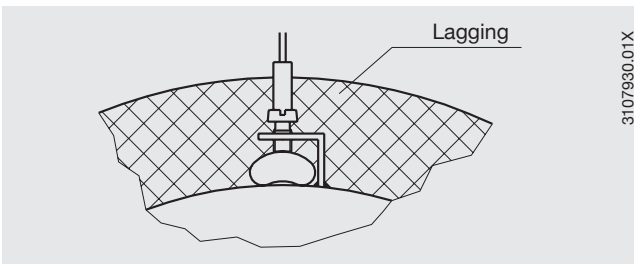
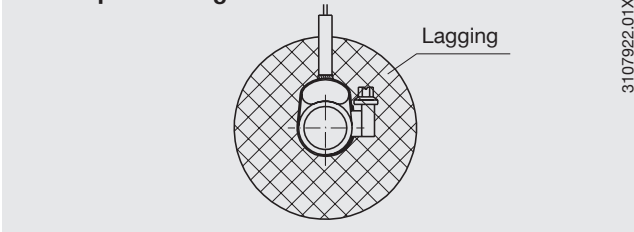

Modifications may take place and materials specified may be replaced by others without prior notice. Specifications and dimensions given in this leaflet represent the state of engineering at the time of printing.

